

D2000 | SWIVEL JOINT

The use of our new, multifunctional swivel joint D2000 optimizes nearly all liquid transports.

THE D2000 CAN BE USED UNIVERSALLY

Whether in the mineral oil, food or chemical industry, the D2000 meets the highest standards. Due to the sandwich design, the bearing module is separated from the product carrying components. Therefore it can be used as a standard swivel joint for nearly all media with temperatures ranging from -45°C to $+250^{\circ}\text{C}$.

- * Complies with TA Luft
(German regulation for environmental protection)
- * Split flanged design

THE D2000 HIGH LOAD CAPACITY & INTEGRITY

Due to the separation of product carrying parts, the material of the bearing module is produced for high load bearing capacity with the ball races being "deep" flame hardened.

THE D2000 HAS A COMPACT DESIGN

The compact dimensions of the D2000 allows it to be used in "low profile" applications.

THE D2000 HAS MANY VARIANTS

The D2000 can be used to fulfill customers own specific requirements. The material of the product carrying parts can have many variants and will depend on the media being handled.

THE D2000 COMPLIES WITH RELEVANT REGULATIONS

The swivel joint is produced according to the requisite regulations for articulated pipework. It can also be adopted to comply with other specific regulations.



THE D2000 HAS A HIGH LEAK PROOF CAPACITY

The D2000 achieves its sealing characteristics due to its smooth rotation and high bending moment characteristics. It fulfils all requirements of the "TA-Luft" (German regulation for environmental protection).

THE D2000 IS LONG-LASTING

The deep flame hardened ball races guarantee a long working life and low wear characteristics.

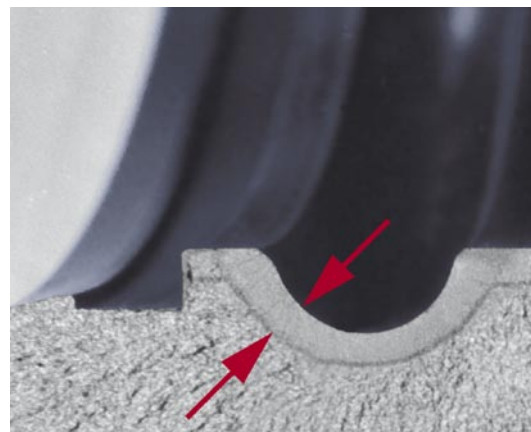

THE D2000 IS MAINTENANCE FRIENDLY

The bearing module and seals can be easily replaced: remove flange, change seal, replace flange - ready for use.

All this without having to disassemble the whole loading arm! This is practical saving time and substantially reduces life cost.

D2000

D2000 | SWIVEL JOINT

TECHNICAL DATA D2000

Size	A	Ø B	Ø C	D	Ø E	F	S	Weight	Working pressure	Test pressure	Temperature*
DN 50	98	151	60.3	33.4	89	42	4	5.6 kg	40 bar	60 bar	-45 °C to +250 °C
DN 80	98	176	88.9	33.4	114	42	5.6	7.2 kg			
DN 100	98	205	114.3	33.4	143	42	6.3	9.2 kg			
DN 150	160	302	168.3	55	216	68	7.1	33.5 kg			
DN 200	180	365	219.1	65	274	68	8.2	47 kg			

* temperature range might be restricted due to seal material

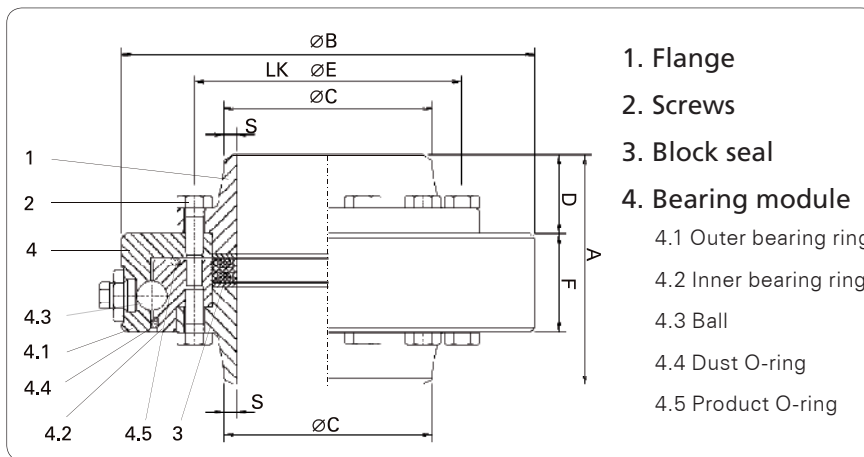

1. Flange
2. Screws
3. Block seal
4. Bearing module
 - 4.1 Outer bearing ring
 - 4.2 Inner bearing ring
 - 4.3 Ball
 - 4.4 Dust O-ring
 - 4.5 Product O-ring

Following are the most common variants:

FLANGES

- * carbon steel
- * low temperature steel
- * stainless steel
- * aluminium

BEARING MODULE

- * carbon steel nickel plated

SEALING MODULE

- * Perbunan
- * Viton
- * FEP
- * EPDM
- * Fluorolyol K
- * PTFE

Other materials for special applications are available on request.

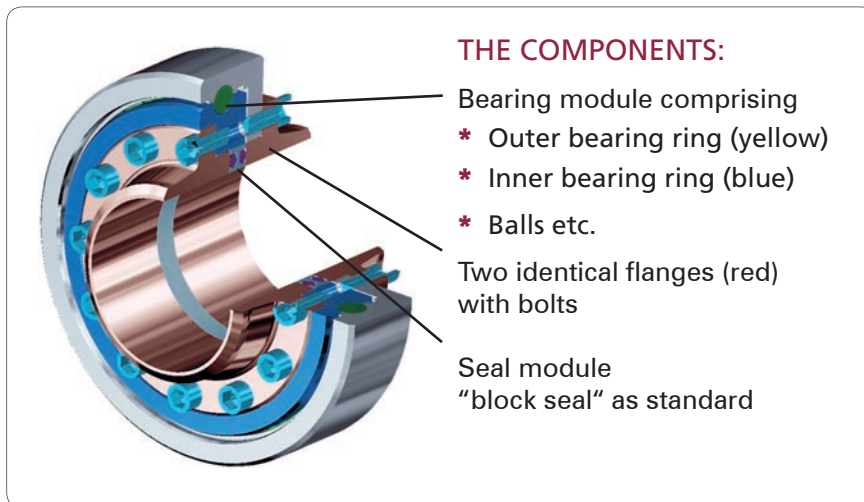

THE COMPONENTS:

- Bearing module comprising
 - * Outer bearing ring (yellow)
 - * Inner bearing ring (blue)
 - * Balls etc.
- Two identical flanges (red) with bolts
- Seal module
"block seal" as standard

Whilst the content of this leaflet has been edited with the greatest care, we are not liable for any errors and/or omissions. Subject to change without notice.

D2000 EN 05/08

Better by Design



EMCOWHEATON

A Gardner Denver Product

EMCO WHEATON GmbH
Emcostraße 2-4 · 35274 Kirchhain · Germany
Phone +49 6422 84-0 · Fax +49 6422 5100
www.emcowheaton.com · info-de@emcowheaton.com